

COUNTERTOP THREE TIER HOT FOOD MERCHANDISER



Royston Countertop Three Tier (HC-STN-3SC)

GRAB THAT LAST MINUTE IMPULSE BUY

Our heated, 3-tier countertop merchandiser with eye-catching T-5 lighting is a brilliant way to grab that last minute impulse buy as a customer approaches the sales counter. Or use it wherever you have counter space that should be driving more high margin sales for your store. It's the perfect small footprint showcase for your hot foods.

STANDARD FEATURES

- Stainless steel construction
- Easy-to-clean, 16-gauge, stainless-steel deck construction
- Attractive, clean appearance with no exposed fasteners
- 1/4" tempered glass sides and top
- Deck surfaces heated with energy-efficient heater pads to provide even heating across entire deck
- Heated shelves constructed from easy-to-clean black SCHOTT CERAN® glass-ceramic
- Each level equipped with independent digital temperature controls
- Tubular heater provides additional top heating on lower shelf
- All controls easily accessed on back panel
- Access doors on back of unit
- Brilliant T-5 lighting
- Prewired breaker panel
- Certified UL Safety and UL Sanitation per NSF standards



Access doors to each shelf on back of unit.



Each level is equipped with digital temperature controls.

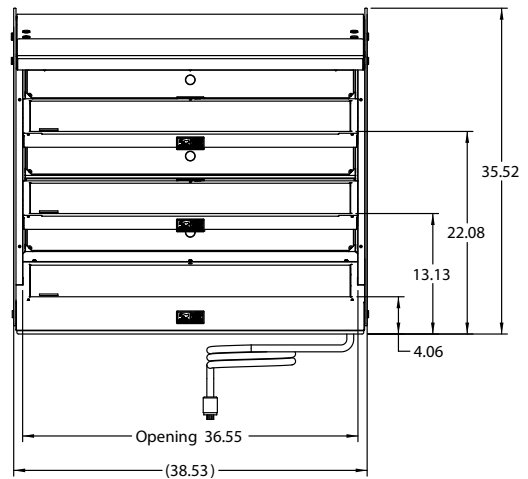
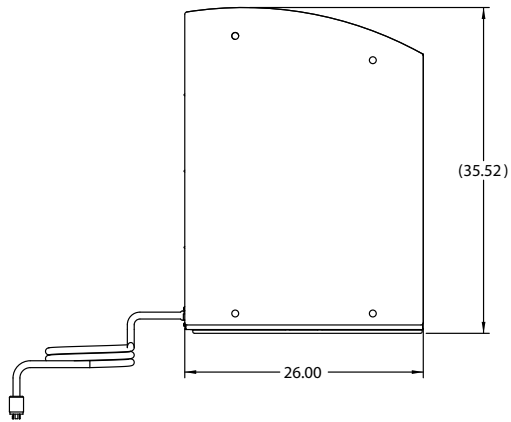

COUNTERTOP 3 LEVEL • HC-STN-3SC - 38.5" x 26" x 35.5"					
ELECTRICAL SPECIFICATION					
Voltage	K Watts	Amps	Service	Plug	
120/208	3.15	15.38	20 Amp	NEMA L14-20P	
HEATED SURFACE AREA					
	Width	Length	Surface Area (sq.in.)		
Top Shelf	20.13	34.88	701.86		
Middle Shelf	20.13	34.88	701.86		
Bottom Shelf	20.13	34.88	701.86		
TOTAL			2105.58		

